

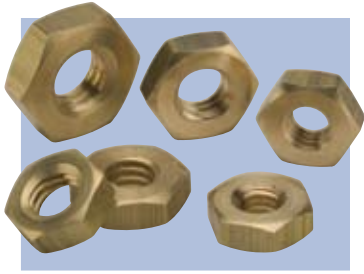

# SERIES H20 HEX JAM NUTS

# SERIES H21 HEAVY HEX JAM NUTS



A jam nut is typically 2/3 the thickness of its respective hex nut series counterpart.

Jam nuts are tightened against the work surface and a heavy hex or finished hex nut is secured against the jam nut to ensure that the nut does not become loose.

Series H20 hex jam nuts are for use with Series H10 finished hex nuts.

Series H21 heavy hex jam nuts are for use with Series H11 heavy hex nuts.



Series H20      Series H21

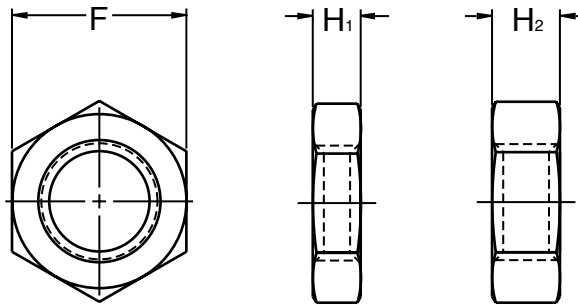

## HEX JAM NUTS, H20 AND H21

Nominal or Basic Major Diameter of Thread and Threads Per Inch	H20 Hex Jam		H21 Heavy Hex Jam	
	F	H <sub>1</sub>	F	H <sub>2</sub>
	Wrench Size	Thickness	Wrench Size	Thickness
1/4 – 20	7/16	5/32	1/2	11/64
5/16 – 18	1/2	3/16	9/16	13/64
3/8 – 16	9/16	7/32	11/16	15/64
7/16 – 14	11/16	1/4	3/4	17/64
1/2 – 13	3/4	5/16	7/8	19/64
9/16 – 12	7/8	5/16	15/16	21/64
5/8 – 11	15/16	3/8	1-1/16	23/64
3/4 – 10	1-1/8	27/64	1-1/4	27/64
7/8 – 9	1-5/16	31/64	1-7/16	31/64
1 – 8	1-1/2	35/64	1-5/8	35/64
1-1/8 – 7	1-11/16	39/64	1-13/16	39/64
1-1/4 – 7	1-7/8	23/32	2	23/32

**MATERIALS:** Brass, 303 Stainless Steel, and Aluminum.

**FINISHES:** Plain, Bright Nickel, Passivated, and Zinc with Chromate. Other finishes available upon request.

**TO ORDER:** Provide Series, thread size - pitch, material and finish.

**EXAMPLE:** H20, 3/4 – 10, Brass, Nickel

# SPIROL®

Innovative fastening solutions.  
Lower assembly costs.



## Challenge Us!

**SPIROL** Application Engineers will review your application needs and work with your design team to recommend the best solution. One way to start the process is to visit our **Optimal Application Engineering** portal at [www.SPIROL.com](http://www.SPIROL.com).

**U.S.A. Spirol International Corporation**  
30 Rock Avenue  
Danielson, Connecticut 06239  
Tel. +1 (1) 860.774.8571  
Fax. +1 (1) 860.774.2048

**Spirol West Inc.**  
1950 Compton Avenue, Unit 111  
Corona, California 92881-6471  
Tel. +1 (1) 951.273.5900  
Fax. +1 (1) 951.273.5907

**Spirol International Corporation  
Shim Division**  
321 Remington Road  
Stow, Ohio 44224  
Tel. +1 (1) 330.920.3655  
Fax. +1 (1) 330.920.3659

**Spirol Distribution**  
(For Distributor Customers)  
30 Rock Avenue  
Danielson, Connecticut 06239  
Tel. +1 (1) 860.774.8571  
Fax. +1 (1) 860.774.0487

**Canada Spirol Industries, Ltd.**  
3103 St. Etienne Boulevard  
Windsor, Ontario  
Canada N8W 5B1  
Tel. +1 (1) 519.974.3334  
Fax. +1 (1) 519.974.6550

**Mexico Spirol México, S.A. de C.V.**  
Carretera a Laredo KM 16.5 Interior E  
Col. Moisés Saenz  
Apodaca, N.L. 66613 México  
ó Apdo. Postal 151 de Apodaca, N.L.  
Tel. +52 (01) 81 8385 4390  
Fax. +52 (01) 81 8385 4391

**Europe Spirol Industries, Ltd.**  
Princewood Road  
Corby, Northants  
England NN17 4ET  
Tel. +44 (0) 1536 444800  
Fax. +44 (0) 1536 203415  
(UK Distributors: Tel. 0800 3890034)

**Spirol SAS**  
Rue Henri Rol Tanguy  
Z.A. Les Naux  
51450 Bétheny - Reims  
France  
Tel. +33 (0) 3 26 36 31 42  
Fax. +33 (0) 3 26 09 19 76

**Spirol GmbH**  
Briener Strasse 9  
80333 Munich  
Germany  
Tel. +49 (0) 931 454 670 74  
Fax. +49 (0) 931 454 670 75

**Asia Pacific Spirol International Engineered  
Fastener Trading Co. Ltd.**  
No. 11 Xi Ya Rd. North  
Section A, 1F, Building 14  
Wai Gao Qiao Free Trade Zone  
Shanghai, China 200131  
Tel. +86 (0) 21 5046-1451/1452  
Fax. +86 (0) 21 5046-1540

e-mail: [info@spirol.com](mailto:info@spirol.com)

[www.SPIROL.com](http://www.SPIROL.com)