

# SPIROL<sup>®</sup>

## PIN INSTALLATION TECHNOLOGY

### Model CRD Semi-Automatic Dual Pin Inserter

Whenever simultaneous multiple-pin insertion is feasible and practical, it should be considered to enhance productivity. This robust, dual vertical pin insertion machine is based on SPIROL's standard **Model CR** design. Able to install two pins simultaneously, it is ideally suited for moderate to high production for applications requiring up to 1,800 lbs (2 pin total) of installation force. A single dual or twin single (based on the center distance needed) retractable pin orientation head, mounted on a shaft/linear bearing arrangement moves up and down for ease of loading and unloading of the assembly components. The installation bushings are positioned close to the parts for smooth, trouble free installation. The orientation head shuttles the pins from the feeding position to the installation position and functions as a selector, preventing longer or shorter pins from being installed. A two position trap door allows easy clear-out of the feed tube without the need for tools.

#### Design Features/Benefits:

- Precise:**
- Fine insertion depth adjustment
  - Doweled component location
  - Ground base plate to ensure perpendicularity between insertion quill and application
- Built to Last:**
- Cushioned cylinder return stroke
  - Hardened pin guide bushings and hard coated vibratory feeder bowls
- Versatile:**
- Can be easily configured to accommodate a variety of applications
- Efficient:**
- Automatically delivers the pins to the installation site eliminating the need to touch the pin during the entire assembly process
- Safe:**
- Guarded pinch points and anti-tie down, anti-repeat dual activation sensors (or optional foot switch with integrated finger protection unit)

**Optional alignment fixtures available.**

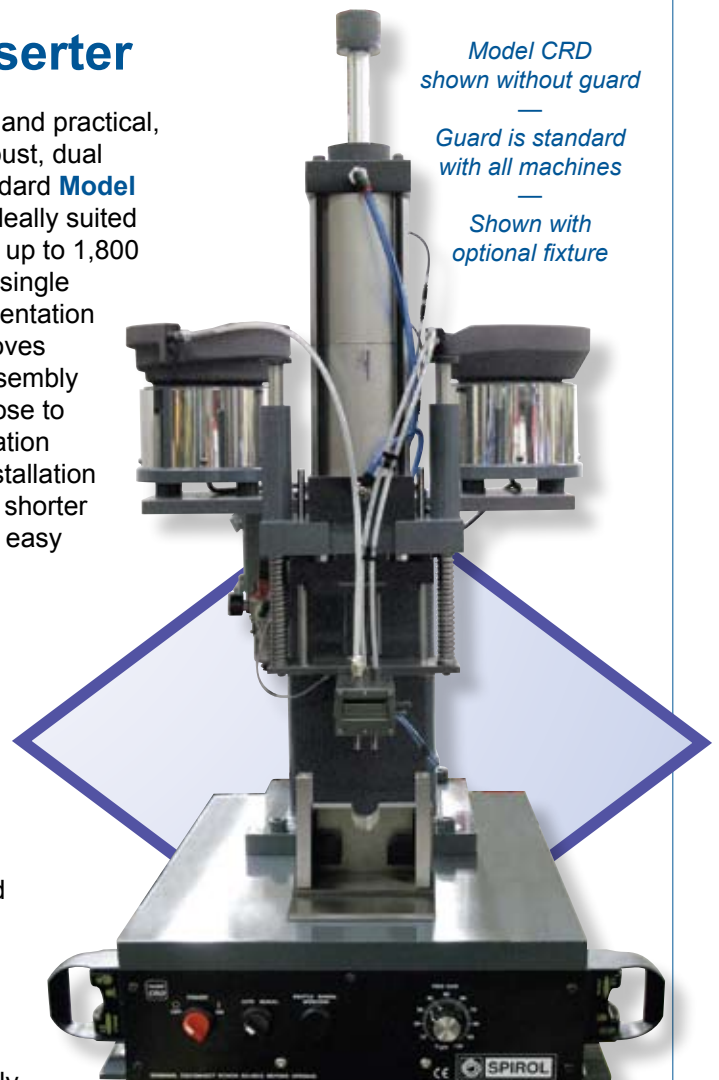

*Options such as rotary index tables, pin sensing, force monitoring, and drilling and pinning combinations can be added for enhanced productivity and heightened error-proofing.*



# Application Engineering

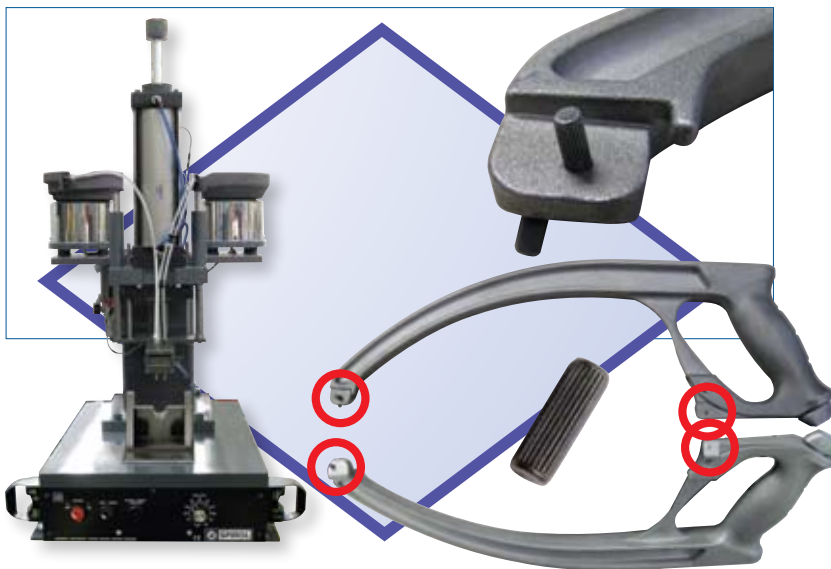

### Application:

A die casting manufacturer is engaged in the production of an all-aluminum hacksaw frame. To affix the cutting blade to the frame, pins are required at each end; one in a fixed position, and the other in an adjustable tensioner component. The pins must be able to withstand rigorous use without failure. An added feature on this saw design are two additional pins, installed at a 45 degree tilt, to allow the user to cut very close to a wall or other obstruction. The objective for installation for all (4) pins is 30 seconds.

### Solution:

**SPIROL** Application Engineers recommended the use of hardened steel **SPIROL Solid Knurled Pins** for the assembly. The **Model CRD Dual Vertical Pin Inserter** was selected to install the pins. Twin insertion mechanisms were mounted at the correct angle and center distance for proper positioning of the pins. The operator loads the saw frame into a holding fixture that utilizes the same datum points used in the machining process for the holes. Upon activation, the insertion head advances, installs two pins, retracts and resets. To pin the second set of holes, the operator rotates the saw about its axis 135 degrees to a spring loaded lock, and then activates the machine again. The completed assembly is removed and the next one loaded. Each pin installation cycle consumes 3 seconds, leaving a generous 24 seconds to load, index and unload.

## Challenge Us!

**SPIROL** Application Engineers will review your application needs and work with your design team to recommend the best solution. One way to start the process is to select Installation Systems in our Optimal Application Engineering portal at [www.SPIROL.com](http://www.SPIROL.com).

**U.S.A. Spirol International Corporation**  
30 Rock Avenue  
Danielson, Connecticut 06239  
Tel. 860.774.8571 Fax 860.774.2048

**Spirol West Inc.**  
1950 Compton Avenue, Unit 111  
Corona, California 92881-6471  
Tel. 951.273.5900 Fax 951.273.5907

**Spirol International Corporation Shim Division**  
321 Remington Road  
Stow, Ohio 44224  
Tel. 330.920.3655 Fax 330.920.3659

**Spirol Distribution**  
30 Rock Avenue  
Danielson, Connecticut 06239  
Tel. 800.321.4679 Fax 860.774.0487  
(For Distributor Customers)

**Canada Spirol Industries, Ltd.**  
3103 St. Etienne Boulevard  
Windsor, Ontario  
Canada N8W 5B1  
Tel. 519.974.3334 Fax 519.974.6550

**Mexico Spirol México, S.A. de C.V.**  
Carretera a Laredo KM 16.5 Interior E  
Col. Moisés Saenz  
Apodaca, N.L. 66613 México  
ó Apdo. Postal 151 de Apodaca, N.L.  
Tel. (81) 8385 4390 Fax (81) 8385 4391

**Europe Spirol Industries, Ltd.**  
Princewood Road  
Corby, Northants  
England NN17 4ET  
Tel. 44 (0) 1536 444800  
Fax 44 (0) 1536 203415  
(For Distributor Customers)  
Tel. 44 (0) 8003 890034

**Spirol SAS**  
Rue Henri Rol Tanguy  
Z.A. Les Naux  
51450 Bétheny  
France  
Tel. 33 (0)3 26 36 31 42  
Fax 33 (0)3 26 09 19 76

**Spirol GmbH**  
Briener Strasse 9  
80333 Munich  
Germany  
Tel. 49 (0) 931 454 670 74  
Fax. 49 (0) 931 454 670 75

**Asia Pacific Spirol International Engineered Fastener Trading Co. Ltd.**  
No. 11 Xi Ya Rd. North  
Section A, 1F, Building 14  
Wai Gao Qiao Free Trade Zone  
Shanghai, China 200131  
Tel. (8621) 5046 1451/1452  
Fax (8621) 5046 1540

e-mail: [info@spirol.com](mailto:info@spirol.com)

**SPIROL.com**

Request a free **SPIROL Automation CD-ROM** that demonstrates the Pin Inserters in operation, presents their versatility, and lists cost-effective options available for your application.